

NEW



RUA Light

RUA Light ▶

Riveted cabinet with removable sides, made of galvanized sheet, IP 30, capacity 25kg if properly mounted.

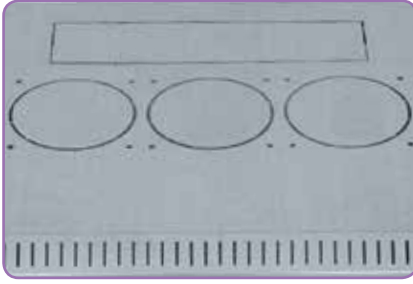

■ VENTILATION

The RUA type has 6 break-out blanking panels for the installation of ventilation units RAX-CH-X2x-X1 or fans RAX-CH-X07-X9 (up to 3 in top and 3 in bottom part of the cabinet). RUA therefore enables installation of devices that in the past could not be cooled sufficiently in wall-mounted cabinets and had to be installed into free-standing cabinets only.



■ ADJUSTABLE VERTICAL RAILS

1 pair of vertical rails, fluently adjustable in any depth of cabinet. This simplifies mounting of the device and organisation of connecting cables.



■ LOADING CAPACITY 25 kg

Loading capacity 25kg, if properly mounted.



■ REMOVEABLE SIDES

Removable sides allow easy access from sides to installed devices. There are locks attached to a frame, with the same key as a front door lock in a standard version.

■ BREAKOUT-TYPE BLANKING PANELS

Cable openings covered with breakout-type blanking panels are ready in the top, bottom and rear part of the cabinet. Use a plastic frame and a blanking panel with a brush, that are parts of the cabinet supply, to seal the cabinet opening against dust penetration.



RUA LIGHT - AS4

TYPE	A	B	C	D	E	R1	R2	Weight gross (kg)	Weight net (kg)	Maximum recommended load (kg)
	(mm)									
RUA-04-AS4-ZAX-A1	280	175	530	600	395	234	420	8,9	8,2	25*
RUA-06-AS4-ZAX-A1	370	265	530	600	395	324	420	9,8	9,1	
RUA-09-AS4-ZAX-A1	500	395	530	600	395	454	420	11,9	11,2	
RUA-12-AS4-ZAX-A1	635	530	530	600	395	589	420	14,1	13,4	
RUA-15-AS4-ZAX-A1	770	665	530	600	395	724	420	16,4	15,6	
RUA-18-AS4-ZAX-A1	900	795	530	600	395	854	420	18,5	17,7	

RUA LIGHT - AS5

TYPE	A	B	C	D	E	R1	R2	Weight gross (kg)	Weight net (kg)	Maximum recommended load (kg)
	(mm)									
RUA-06-AS5-ZAX-A1	370	265	530	600	495	324	420	11,4	10,8	25*
RUA-09-AS5-ZAX-A1	500	395	530	600	495	454	420	14,3	13,5	
RUA-12-AS5-ZAX-A1	635	530	530	600	495	589	420	16,7	15,9	
RUA-15-AS5-ZAX-A1	770	665	530	600	495	724	420	19,2	18,4	
RUA-18-AS5-ZAX-A1	900	795	530	600	495	854	420	21,8	21,0	

* in case of proper hanging

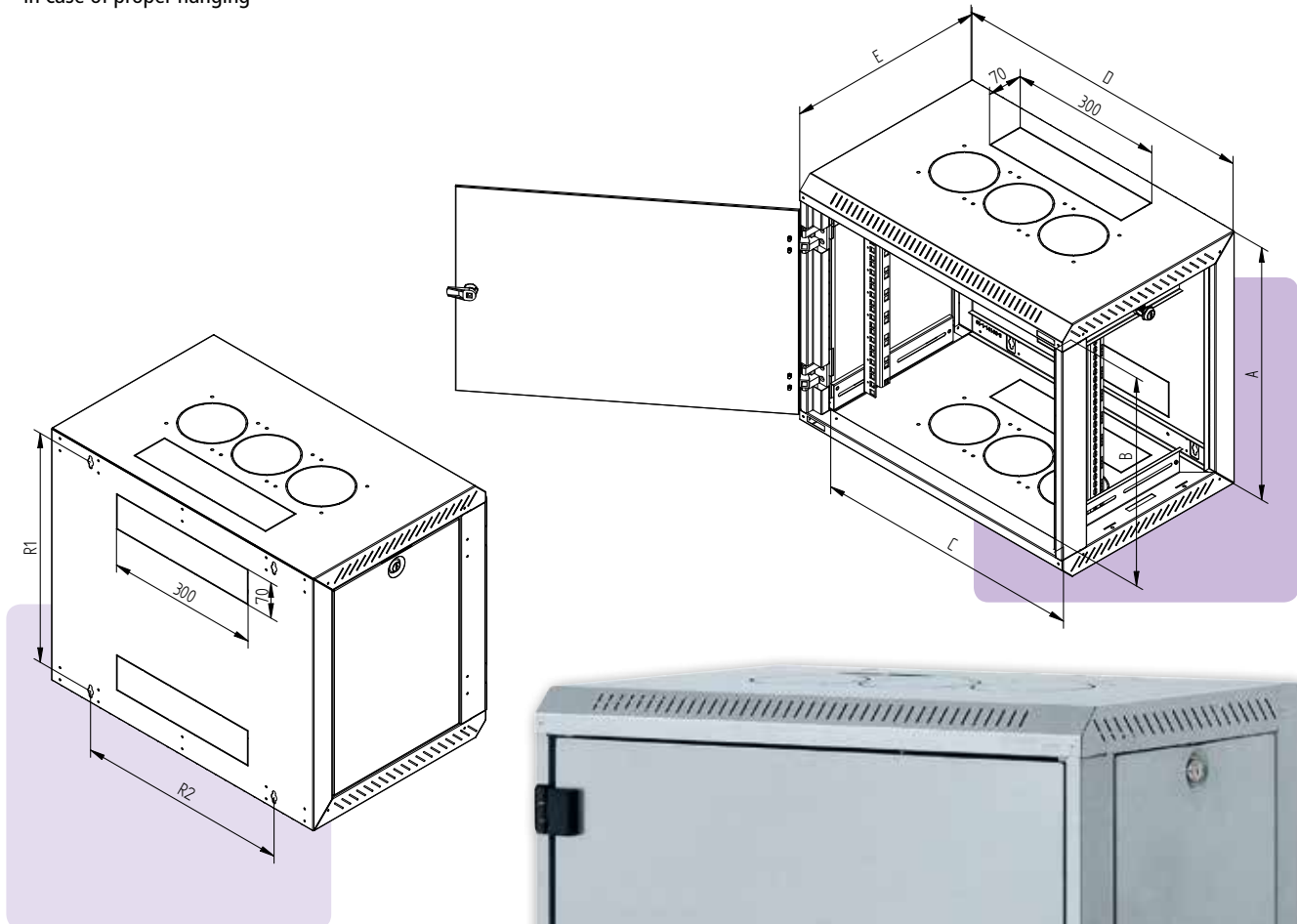

■ DOOR

The cabinet has fully glass door in standard. It can be steel or perforated if required



RUA LIGHT WALL-MOUNTED CABINET

■ DESCRIPTION, PURPOSE OF USE

- 19" one-sectioned wall-mounted cabinet with IP30 protection
- Removable side panels secured by locks.
- Cabinet is to be hanged right on the wall.
- Cabinet includes two sliding vertical rails.
- Cabinet construction:
 - Riveted frame with removable sides secured by locks.
 - Safety hardened glass door, thickness 4 mm. On demand may be metal or perforated.
- Max. permissible load of the door is 5 kg.
- Cabinets are intended for installation of data and telecommunication devices and their distribution systems.
- There is screw M5 as a main grounding point placed at the back of the cabinet.
- Cable openings covered with breakout-type blanking panels are placed in the top and the bottom part of the cabinet rear side, others are in the top and the bottom side of cabinet.
- There are several openings in the top and bottom part of the cabinet which allow to install ventilation units and which are covered with break-out blanking panels.

■ OPERATING CONDITIONS

- Operating environment:
 - Office
 - The cabinet is not intended for outdoor installations and for installations in environment that can influence negatively the functionality of the cabinet and the mounted devices (e.g. environment with danger of explosion or humid and wet surroundings)
- Must be protected against:
 - Mechanical damage
 - Improper handling
 - A different usage than the cabinet is intended for
- Improper handling is especially:
 - Overloading (exceeding the maximum recommended load)
 - Device installation that can influence negatively operation and function of the cabinet or the installed equipment
 - Change of the construction or design of the cabinet

■ INSTALLATION OF THE CABINET

- This type of cabinet is to be hanged on the wall using screws, dowels and washers (part of a supply). Spacing of holes designed for hanging is shown in the scheme („R”).
- To secure the maximum recommended load, it is necessary to fix the cabinet on the wall with an appropriate carrying capacity (brick, concrete or similar) and to distribute the installed loading equally.
- To avoid dust penetration in the case where cables lead through some of the cable openings, it may be sealed with a blanking panel with a brush or secured by a plastic frame (both are included in the delivery).

■ ENVIRONMENTAL PROTECTION

- All parts are made of recyclable materials and after decommissioning the cabinet, it must be disposed of according to relevant regulations.

■ CERTIFICATE AND CONFORMITY

- This product is fully in accordance with ČSN EN 62208 ed.2:2012.